

# HIAB T-HIDUO 013



# HIAB T-HIDUO 013 BASIC DATA

Technical data	HIDUO 013-1	HIDUO 013-2	HIDUO 013-3
Max. lifting capacity (kNm)	11.9	11.7	11.4
Lifting capacity (tm)	1.2	1.2	1.2
Outreach / lifting capacity, hydraulic extension (m/kg)	1.2/995 2.0/590	1.3/920 2.1/540 3.1/360	1.4/840 2.2/500 3.2/330 4.2/250
Outreach / lifting capacity, manual extension (m/kg)	3.1/380 4.2/270	4.2/260	
Outreach, hydraulic extensions (m)	0.8	1.8	2.8
Hydraulic boom extensions (m)	2	3.1	4.2
Outreach, manual extensions (m)	2.2	1.1	
Lifting height above installation level (m)	3.2	4.2	5.2
Manual lifting height above installation level inc. Manual ext.(m)	5.2	5.2	
Recommended oil flow (l/min)	5	5	5
Power needed at rec. oil flow (kW)	1.5	1.5	1.5
Max. working pressure (MPa)	17.5	17.5	17.5
Tank Capacity PTO (l)	18	18	18
Slewing angle (°)	322	322	322
Max. slope viable at full capacity (°)	5	5	5
Slewing torque, gross (kNm)	3	3	3
Slewing speed (°/s)	19	19	19
Height in folded position (mm)	1425	1425	1425
Width in folded position static mounted (mm)	785	785	785
Width in folded position truck mounted (mm) no stab beam/with stab beam and tilting	1826/1926	1826/1926	1826/1926
Installation space needed static mounted (mm)	300	300	300
Installation space needed truck mounted (mm)	426	426	426
Weight, static mounted (kg)	142	172	202
Weight, mounting frame plus 2 short hydr. stabilizer legs (kg)	90	90	90

*This table shows a few examples of models, and represents some of all options available. With the opportunity to configure your crane, we can provide you with a crane perfectly tailored to your needs.*

*Please contact your local dealer for more information on the variety of options we can offer.*

# HIAB T-HIDUO 013-1

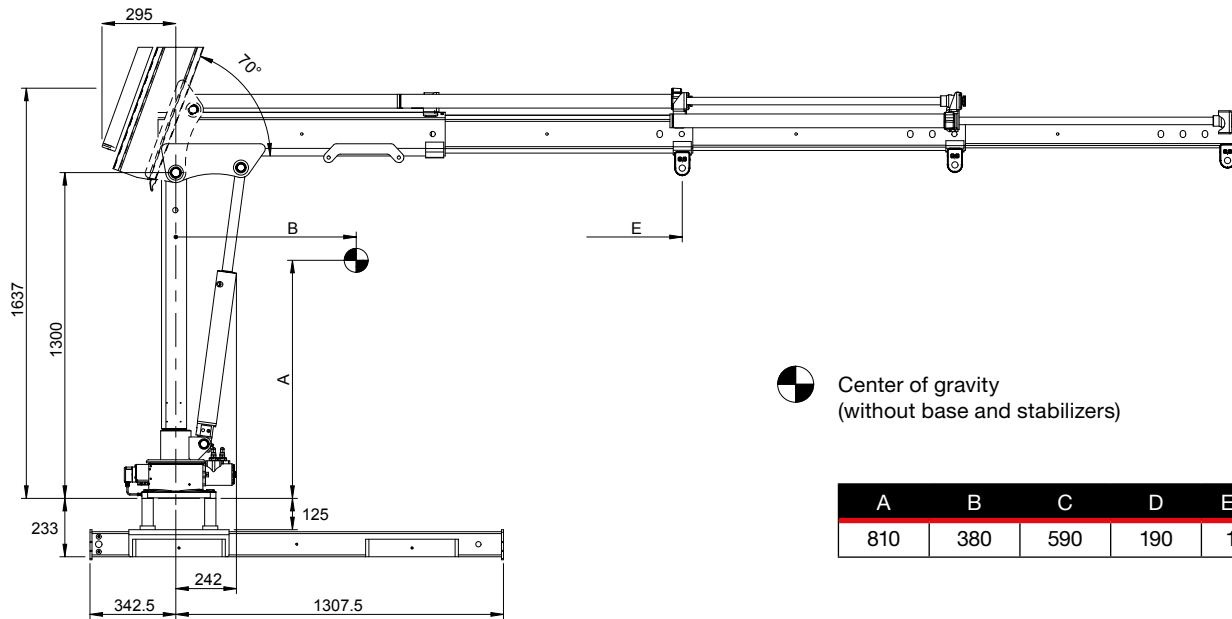

 Center of gravity  
(without base and stabilizers)

A	B	C	D	Emin.	Emax.
810	380	590	190	1121	2021

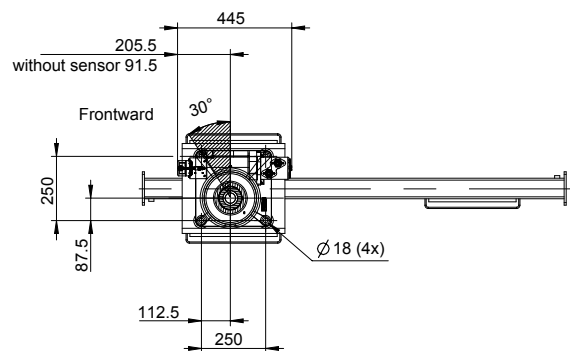
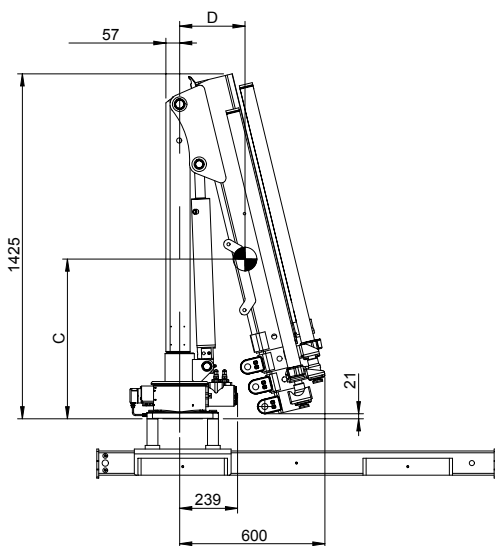

## Capacity plate HIAB T-HIDUO 013-1

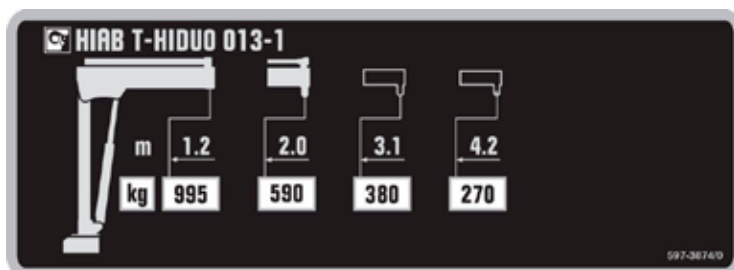

## Load diagram HIAB T-HIDUO 013-1

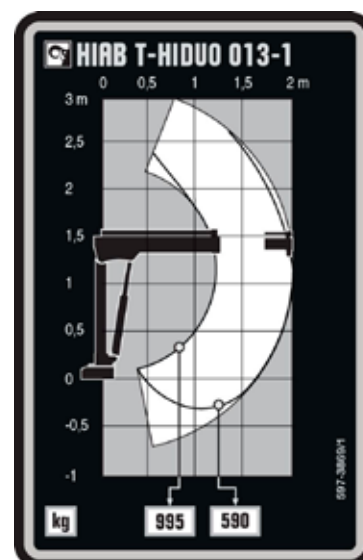

# HIAB T-HIDUO 013-2

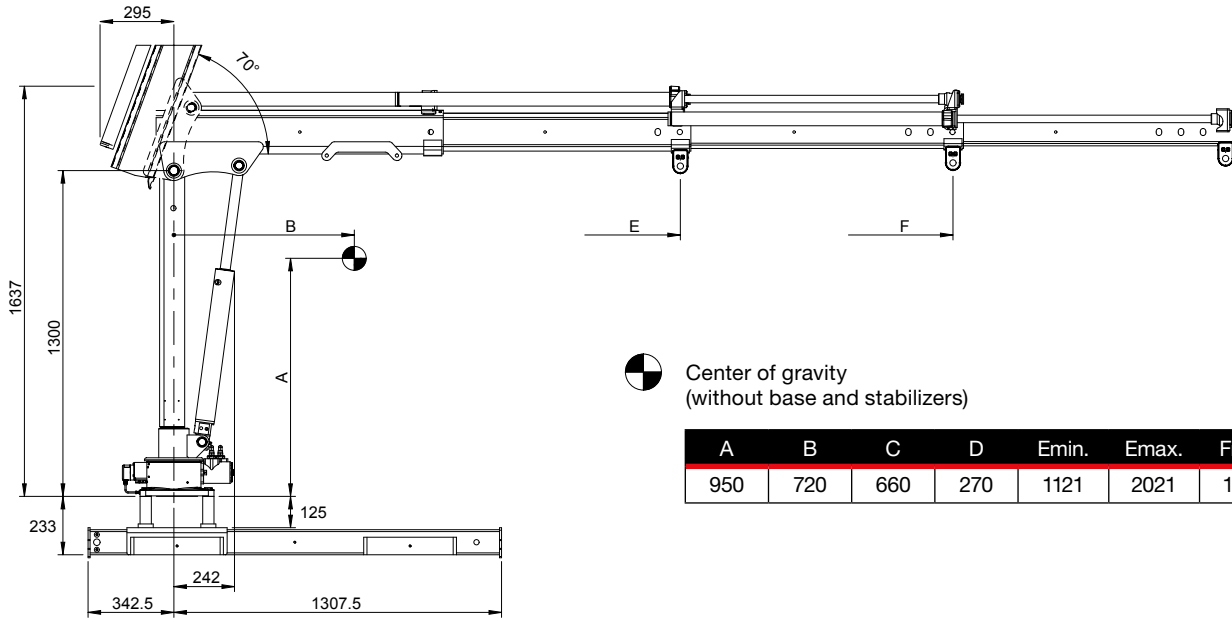

A	B	C	D	Emin.	Emax.	Fmin.	Fmax.
950	720	660	270	1121	2021	1209	3109

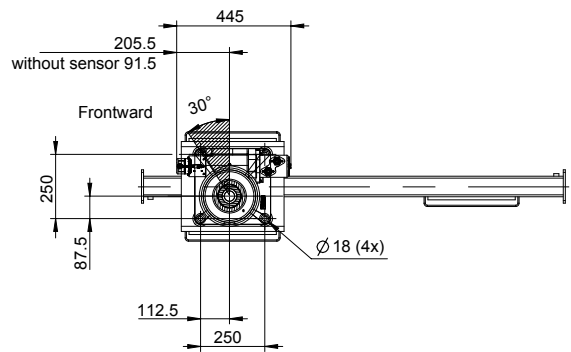
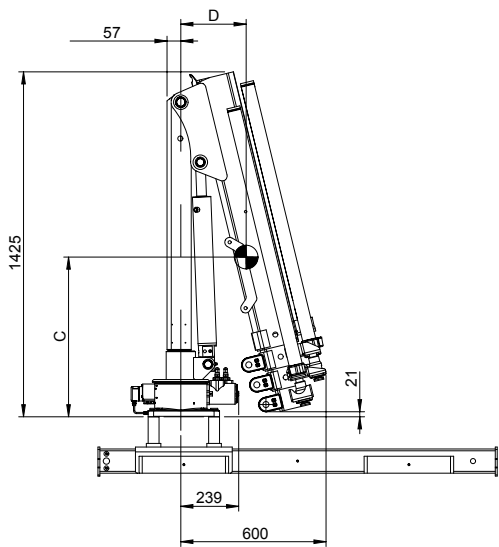

## Capacity plate HIAB T-HIDUO 013-2

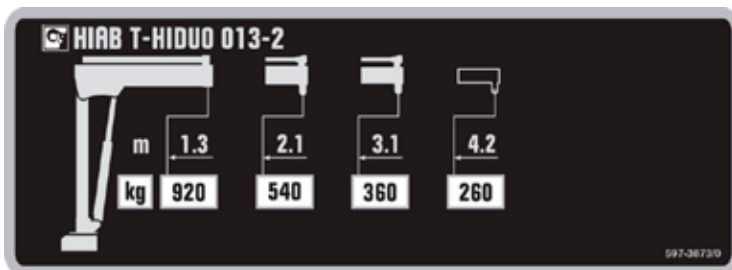

## Load diagram HIAB T-HIDUO 013-2

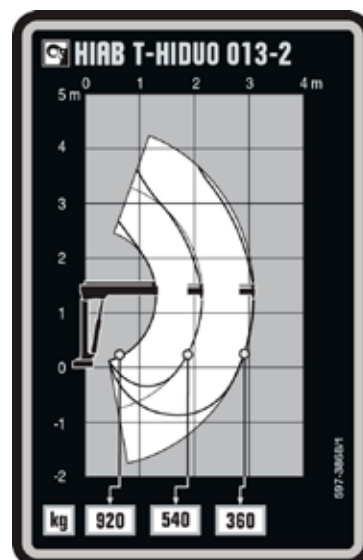

# HIAB T-HIDUO 013-3

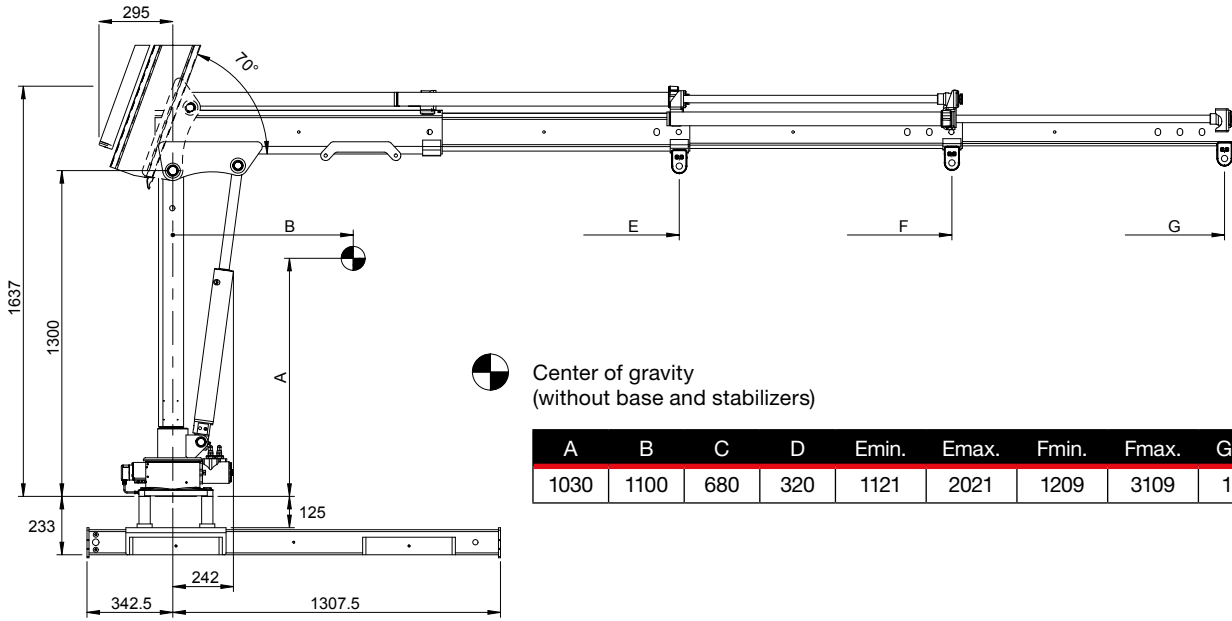

Center of gravity (without base and stabilizers)

A	B	C	D	Emin.	Emax.	Fmin.	Fmax.	Gmin.	Gmax.
1030	1100	680	320	1121	2021	1209	3109	1297	4197

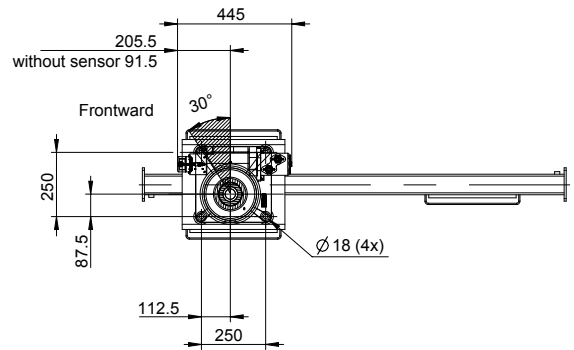
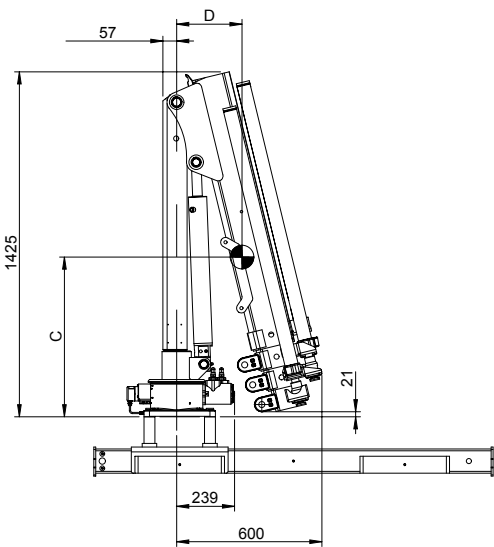

## Capacity plate HIAB T-HIDUO 013-3

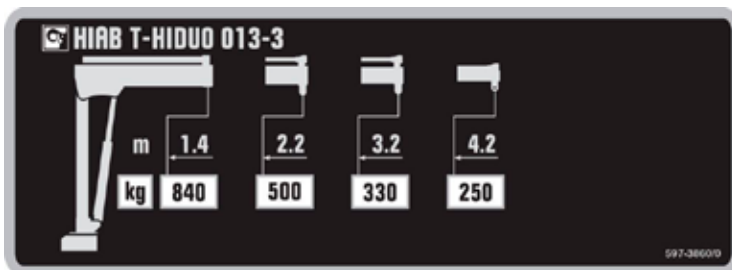

## Load diagram HIAB T-HIDUO 013-3

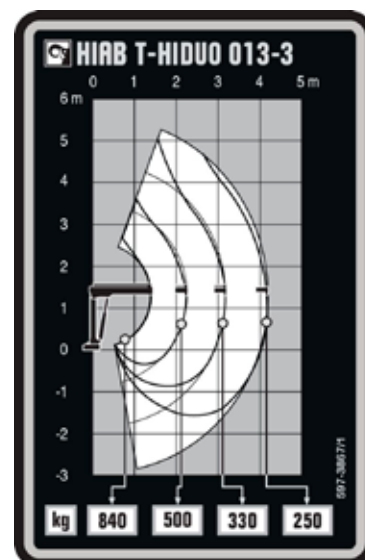

HIAB T-HIDUO 013

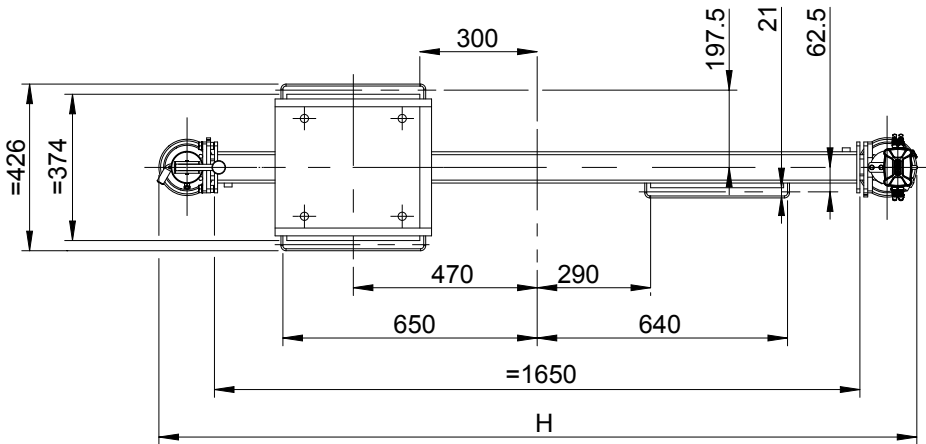

Base	H
Fixed Stabilizer	1826
Fixed Tilttable Stabilizer	1886
Stabilizer With Outrigger	1866
Tilttable Stabilizer With Outrigger	1926

Tilttable stabilizer leg parking positions

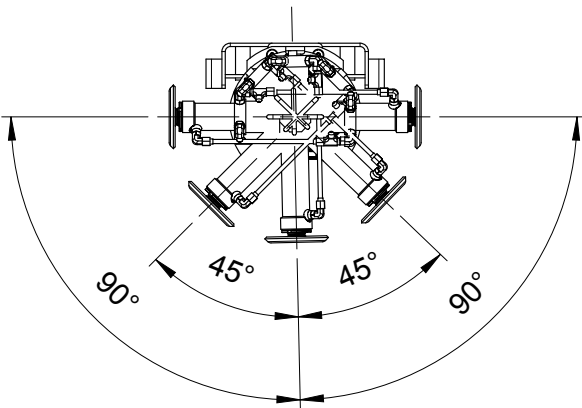

# HIAB T-HIDUO 013

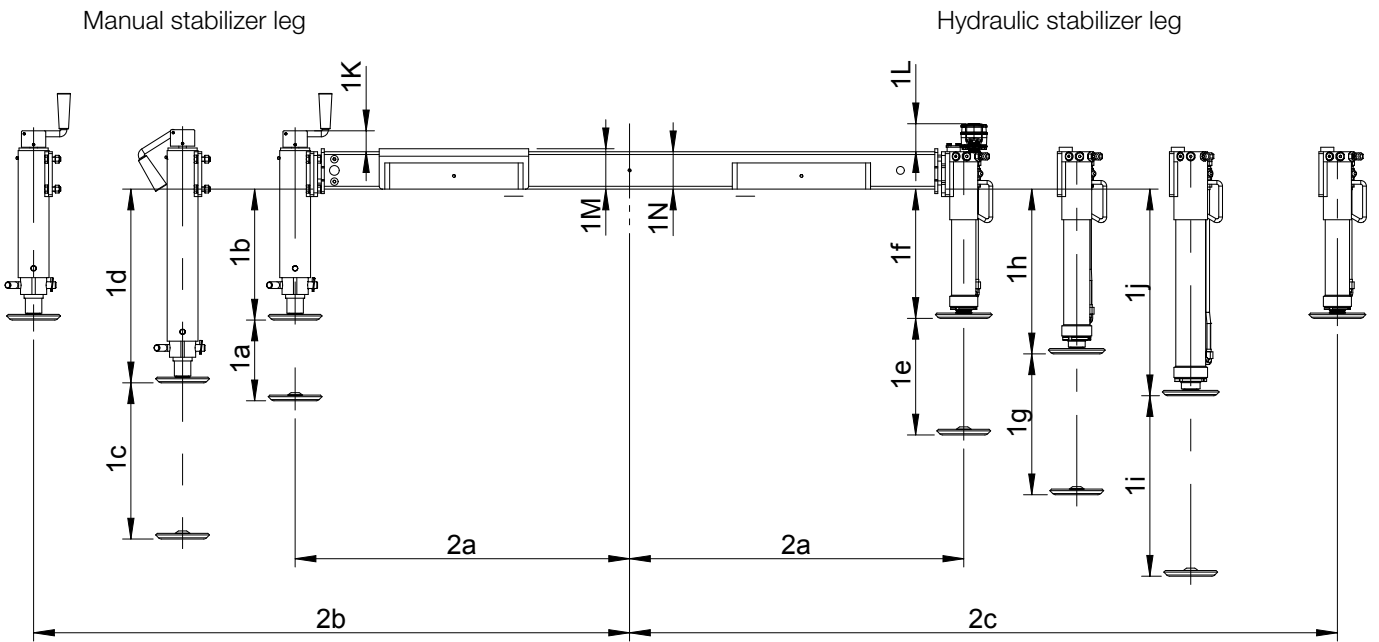

## Other base dimensions

	Fixed stabilizer leg position	Tiltable stabilizer leg
1K	56	33
1L	75	52
1M	108	108
1N	100	100

## Stabilizer leg length

		Fixed stabilizer leg		Tiltable stabilizer leg	
Manual stabilizer leg	Short	1a	216	216	
		1b	350.5	373.5	
	Medium	1c	418	418	
		1d	518.5	541.5	
Hydraulic stabilizer leg	Short	1e	312	312	
		1f	346	369	
	Medium	1g	377	377	
		1h	441	464	
	Long	1i	483	483	
		1j	553	576	

## Base width

		Fixed stabilizer leg	Outrigger beam length Short (300 mm)	Outrigger beam length Medium (800 mm)
Fixed stabilizer leg position	2a	875	895	895
	2b	-	1195	1695
	2c	-	1195	-
Tiltable stabilizer leg	2a	905	925	925
	2b	-	1225	1725
	2c	-	1225	-

# BUILT TO PERFORM

Hiab is the world's leading provider of on-road load handling equipment. Customer satisfaction is the first priority for us. Hiab's product range includes HIAB loader cranes, JONSERED recycling and forestry cranes, LOGLIFT forestry cranes, MOFFETT truck mounted forklifts and MULTILIFT demountables, as well as DEL, WALTCO and ZEPRO tail lifts.

[hiab.com](http://hiab.com)

Hiab is part of Cargotec.

[cargotec.com](http://cargotec.com)

**Disclaimer.** We reserve the right to make changes. Illustrations, drawings and data are not always in accordance with the latest version or standard model in production. The models in the pictures may present special equipment or colours.

TD-THIDUC0018-EN-EU\_151110